

NSX/NSN

Stainless steel
horizontal single
stage centrifugal
pump

Applications

Cooling water
Water supply/distribution
Drainage
General industrial services



Description

Horizontal single-stage centrifugal pumps made in Stainless Steel. Standard totally enclosed, fan cooled, insulation class F, IP 55 motors. Single phase motors up to 2,2 kW.

Standard versions are suitable for smart pumping of clean water with a temperature range between -20 °C and 100 °C.

Performance range

Capacity: Q up to 200 m³/h

Head: H up to 70 m

Temperature: T up to 100 °C

Speed: n 2900 rpm or 3500 rpm

Power: P up to 37 kW

Standard material

All the parts in contact with the liquid are made in AISI304 Stainless Steel. Standard mechanical seals made in Carbon / Silicon Carbide. Other specifications are available upon request.

Performance scope

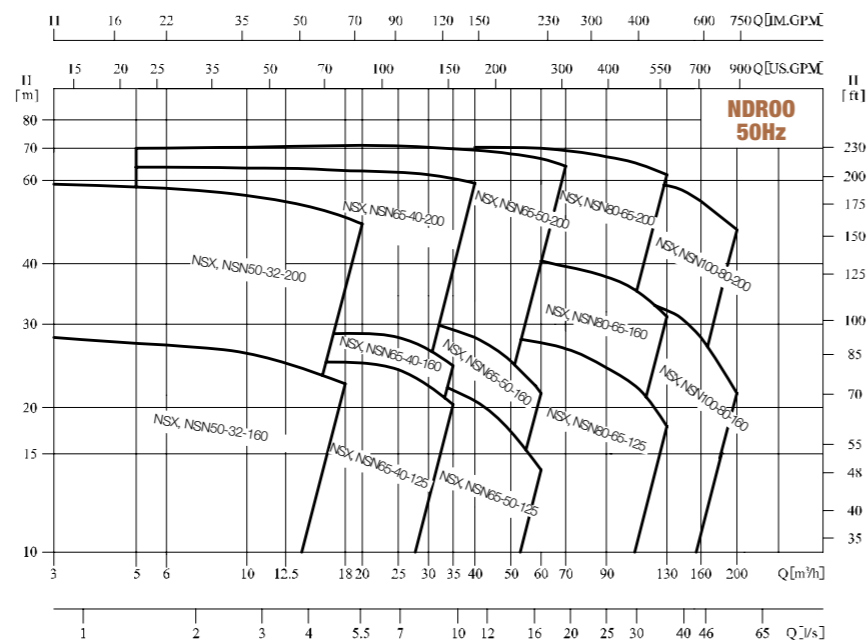

Definition of model

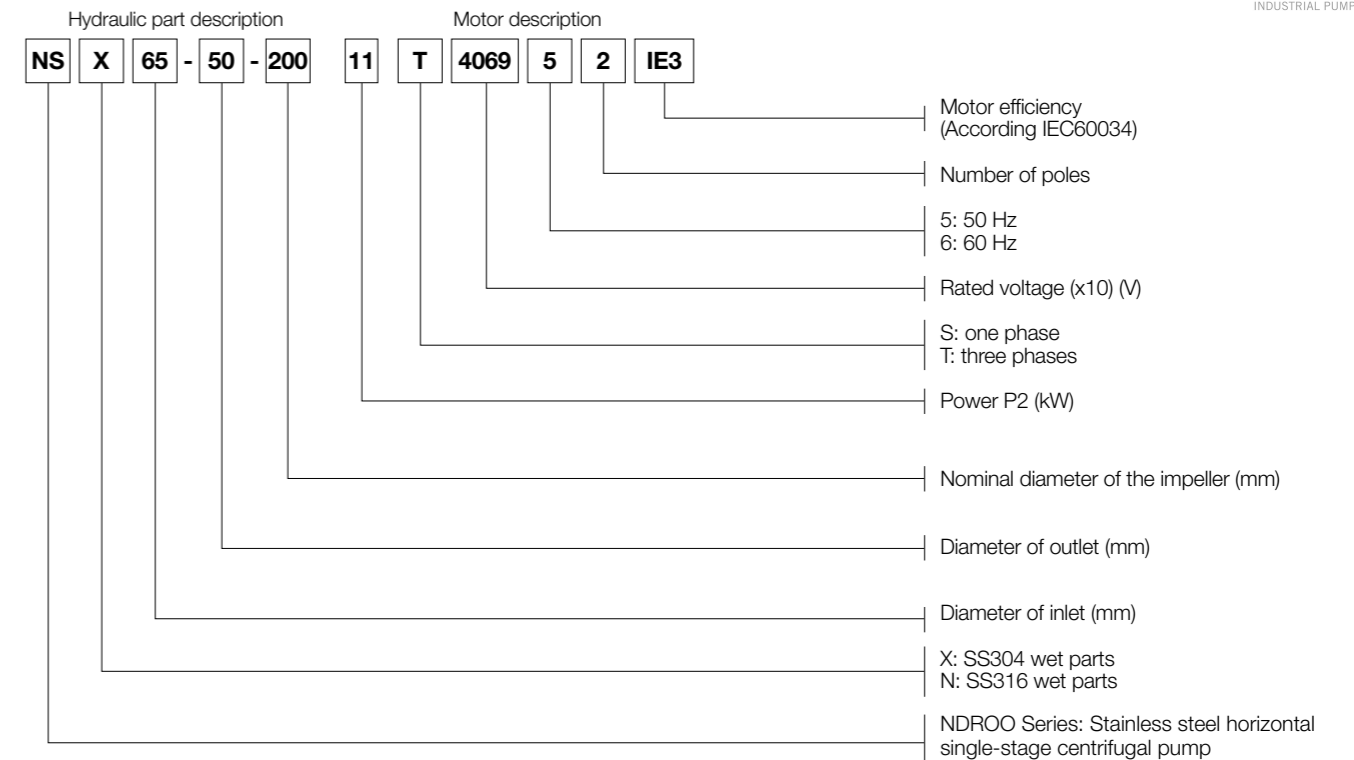

Introduction

NDROO stainless steel horizontal single stage pumps are made to provide a high-end solution for the most demanding pump installations. This range of pumps are made by pressing and laser welding technologies to bring a corrosion resistant pump casing. These pumps are designed to provide a light solution according to EN733, with a high efficiency, energy saving, low noise, corrosion proof, durable and reliable operation.

Application

NDROO range are suitable for a wide range of applications. NDROO is suitable to handle water and any low chemical aggressive liquids for irrigation, HVAC and industrial applications. A wide range of fluid temperature allows NDROO be a satisfactory solution for the most demanding pumping conditions. Main applications are:

- Water supply, filtration, boosting and water transfer.
- Industrial pressurization in cleaning systems and spraying systems.
- Industrial liquids transferring in boiler feed, condensed water, cooling and heating, air conditioned, machine tools, light acid and alkali pumping.
- Water treatment systems, distilled water, separator and swimming-pools
- Irrigation, fertilisers pumping systems, sanitation and medicine installations.

Curves

Following conditions are suitable for the performance curves shown below:

1. Curve tolerance is in conformity with ISO9906 Annex A.
2. All curves are based on the measured value of motor 3x380V, 50Hz: under the constant speed of 2900rpm or 2950rpm.
3. The test medium is clear 20°C water without any solid impurity.
4. Pumps should not work if the flow is beyond the minimum or the maximum flow in the curves.
5. The motor power shall be adjusted if the viscosity or density of medium is different from water.

Motor

- TEFC motor, 2-pole.
- Protection class: Ip55.
- Insulation class: F.
- Standard voltage: 50Hz
1x 220V
3 x 380 V.

Minimum inlet pressure NPSH

Cavitation might happen when pressure in the inlet pump side is lower than the steam pressure for a given liquid and suction conditions. In order to avoid this phenomenon a minimum pressure shall be guaranteed at the pump inlet side. Use the following calculation to assure the optimal suction operation conditions:

$$H = P_b \times 10.2 - NPSH - H_f - H_v - H_s$$

P_b -Atmosphere pressure (bar)
In a closed system, P_b means system pressure (bar).

NPSH-Net positive suction head (m)
It can be read from the point of Max. flow rate shown on NPSH curve.

H_f -Pipeline loss at the inlet (m)
It is in accordance with pipeline possible Max. Flow.

H_v -Steam pressure (m)
It depends on liquid temperature and steam pressure value.

H_s -Safety margin (m)
Minimum 0.5 delivery head
If the calculated result H is positive, the pump may run under the Max.

Suction head H . In case the calculated H is negative, a delivery head of Min. Inlet pressure is necessary.

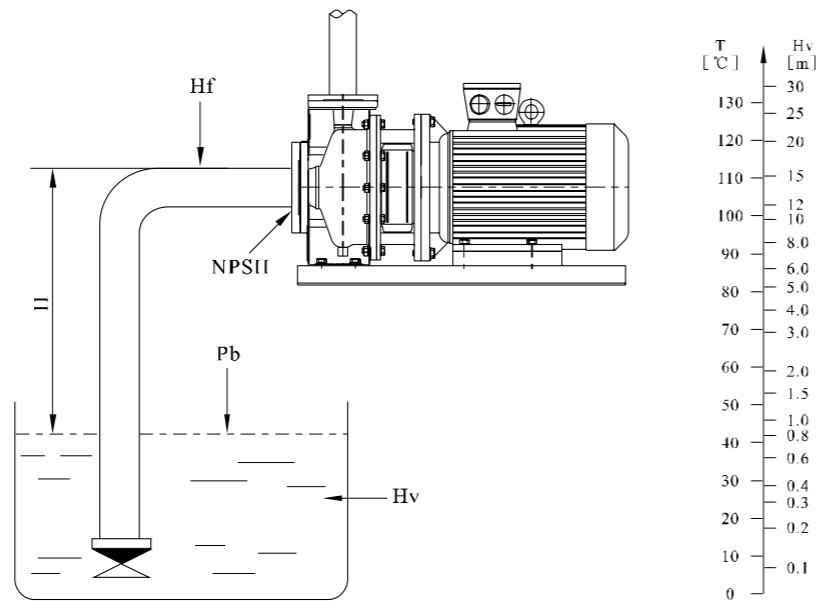

Installation requirements

The shaft connection type of NDROO pump is direct connection. The pump is composed of pump, shaft and standard motor.

– The pump shall be installed on the ventilating and anti-freezing place.

– The installation of the pump shall ensure that the pump will not be forced by the tension of the pipeline.

– If the pump is installed outdoor, suitable outer cover must be used to prevent electric elements from water inflow or coagulating dew.

– To facilitate inspection and maintenance, enough space must be left around the machine group.

– Electric wiring device shall guarantee that the pump will not be damaged by lack of phase, unstable voltage, current leakage and overload.

Note: Normally, the above calculation will not be done. H is calculated in the following conditions:

1. The liquid temperature is comparatively higher.
2. Liquid flow exceeds rated value
3. Suction head is comparatively large or inlet pipeline long.
4. System pressure is too low.
5. Bad inlet condition.

Section drawing

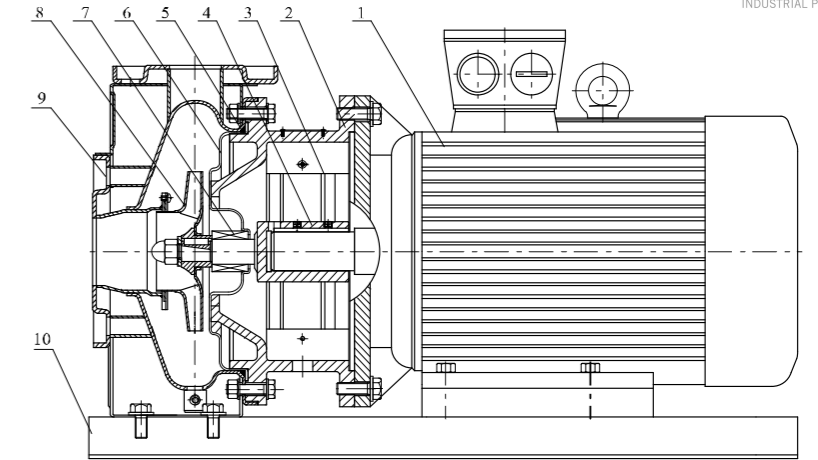

Material

N°	Parts	Material	AISI/ASTM
1	Motor		
2	Pump head	HT200	ASTM25B
3	Guard plate	0Cr18Ni9	AISI304
4	Shaft	2Cr13/0Cr18Ni9	AISI420/AISI304
5	O ring	NBR	
6	Lining of pump head	0Cr18Ni9	AISI304
7	Mechanical sea	Carbon/Silicon Carbide	
8	Impeller	0Cr18Ni9	AISI304
9	Casing	0Cr18Ni9	AISI304
10	Base plate	Q235	ASTMA570

Operating condition

– Clean, thin, non-flammable and explosive, not containing the liquid with solid particle and fibre.

– Liquid temperature: $-20^{\circ}C \sim +100^{\circ}C$.

– Ambient temperature: up to $+40^{\circ}C$.

– Altitude: up to 1000m.

– Max. pressure of the system is 10 bar.

Scope of performance

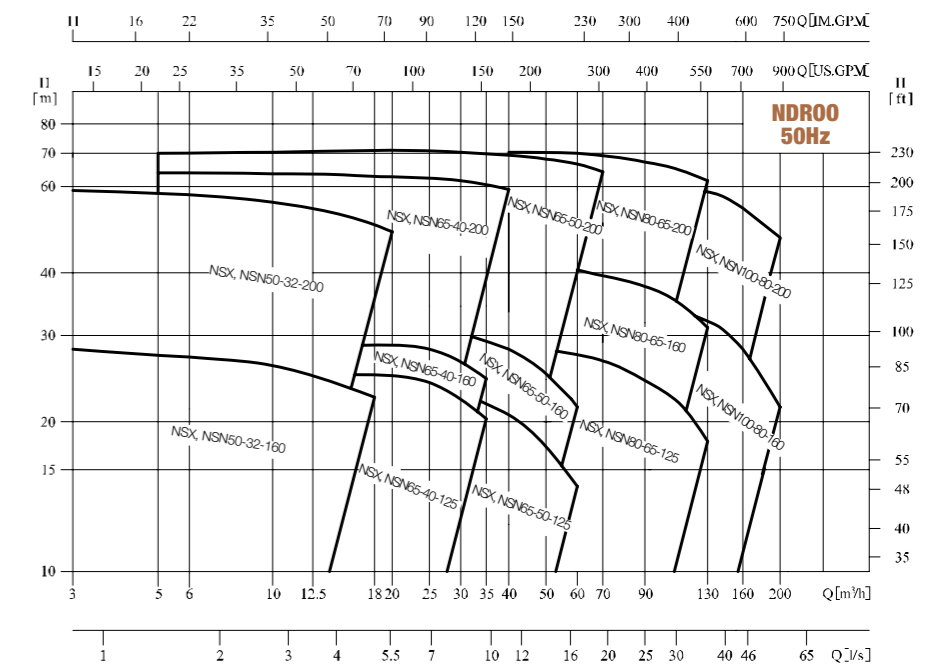

N°	Model	Q (m³/h)	H (m)	n (r/min)	Standard voltage (V)	
					1x220V	3x380V
					P2 (kW)	P3 (kW)
1	NSX, NSN 50-32-160/1.1	6.3	18	2900	1.1	1.1
2	NSX, NSN 50-32-160/1.5	12.5	20		1.5	1.5
3	NSX, NSN 50-32-160/2.2	12.5	25		2.2	2.2
4	NSX, NSN 50-32-200/3.0	12.5	32			3
5	NSX, NSN 50-32-200/4.0	12.5	42			4
6	NSX, NSN 50-32-200/5.5	12.5	54			5.5
7	NSX, NSN 65-40-125/1.5	25	13		1.5	1.5
8	NSX, NSN 65-40-125/2.2	25	18		2.2	2.2
9	NSX, NSN 65-40-125/3.0	25	24			3
10	NSX, NSN 65-40-160/4.0	25	23			4
11	NSX, NSN 65-40-200/5.5	25	36			5.5
12	NSX, NSN 65-40-200/7.5	25	46		7.5	
13	NSX, NSN 65-40-200/11.0	25	62	2950		11
14	NSX, NSN 65-50-125/3.0	50	13	2900		3
15	NSX, NSN 65-50-125/4.0	50	18			4
16	NSX, NSN 65-50-160/5.5	50	25			5.5
17	NSX, NSN 65-50-200/7.5	50	32			7.5
18	NSX, NSN 65-50-200/9.2	50	40			9.2
19	NSX, NSN 65-50-200/11.0	50	48			11
20	NSX, NSN 65-50-200/15.0	50	58	2950		15
21	NSX, NSN 65-50-200/18.5	50	68			18.5
22	NSX, NSN 80-65-125/5.5	100	13	2900		5.5
23	NSX, NSN 80-65-125/7.5	100	18			7.5
24	NSX, NSN 80-65-125/9.2	100	23			9.2
25	NSX, NSN 80-65-160/11.0	100	27	2950		11
26	NSX, NSN 80-65-160/15.0	100	36			15
27	NSX, NSN 80-65-200/18.5	100	45			13.5
28	NSX, NSN 80-65-200/22.0	100	53			22
29	NSX, NSN 80-65-200/30.0	100	66			30
30	NSX, NSN 100-80-160/11.0	160	15			11
31	NSX, NSN 100-80-160/15.0	160	22			15
32	NSX, NSN 100-80-160/18.5	160	28			18.5
33	NSX, NSN 100-80-200/22.0	160	33			22
34	NSX, NSN 100-80-200/30.0	160	45			30
35	NSX, NSN 100-80-200/37.0	160	54		37	

NSX, NSN 50-32



NSX, NSN 50-32-***

ISO9906 Annex A

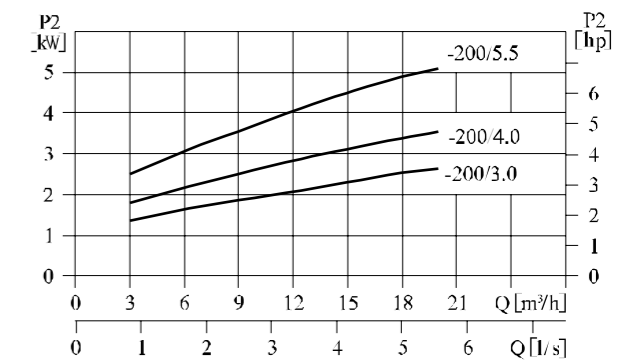
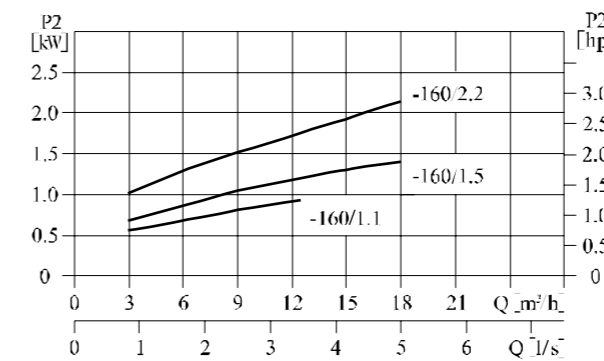
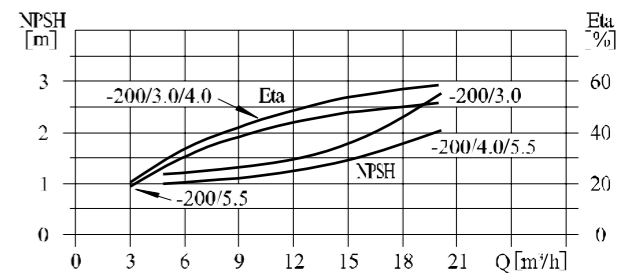
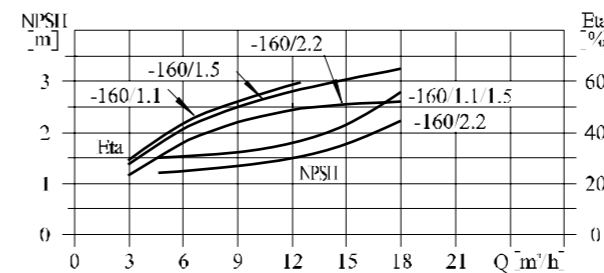
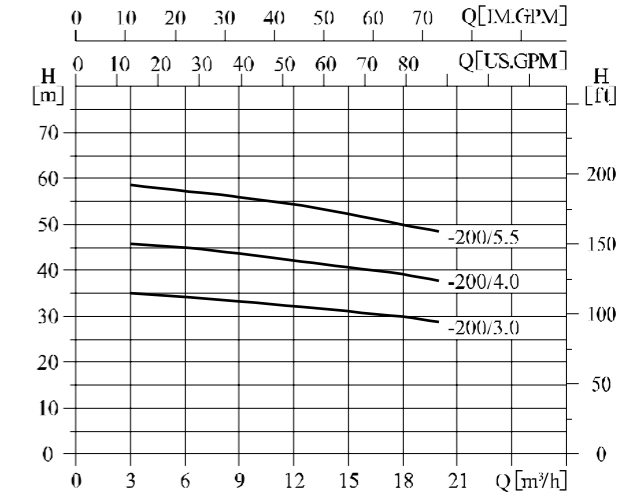
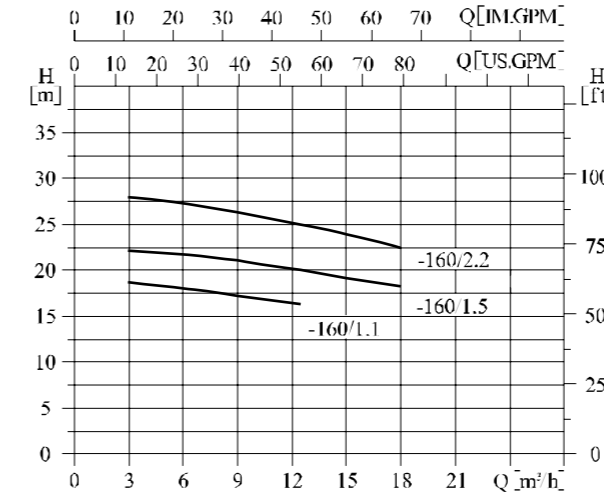

Performance table

Model	Driving motor (kW)		Q (m³/h)	3	6.3	9	12.5	15	18	20
	(kW)	(hp)								
NSX, NSN 50-32-160/1.1	1.1	1.5	H (m)	18.7	18	17.2	16.4			
NSX, NSN 50-32-160/1.5	1.5	2		22.5	22	21	20	19	18	
NSX, NSN 50-32-160/2.2	2.2	3		28	27	26.3	25	24	22.5	
NSX, NSN 50-32-200/3.0	3	4		34.9	34.1	33.3	32	31	29.8	28.9
NSX, NSN 50-32-200/4.0	4	5.5		45.7	44.8	43.7	42	40.7	39	37.7
NSX, NSN 50-32-200/5.5	5.5	7.5		58.5	57.2	56	54	52.5	50	48.5

NSX, NSN 65-40

NSX, NSN 65-40-***

ISO9906 Annex A

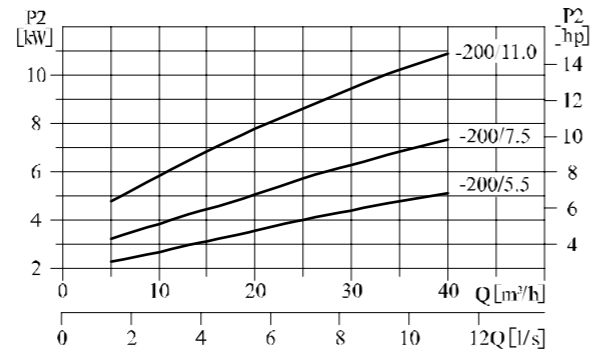
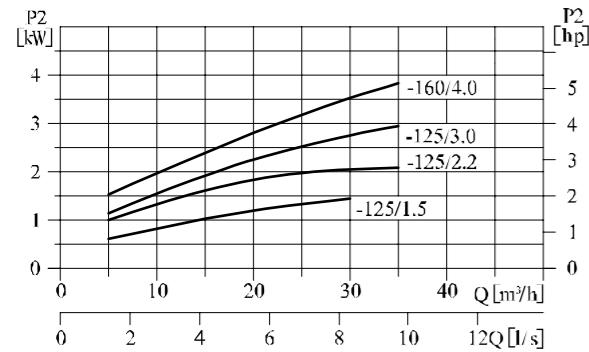
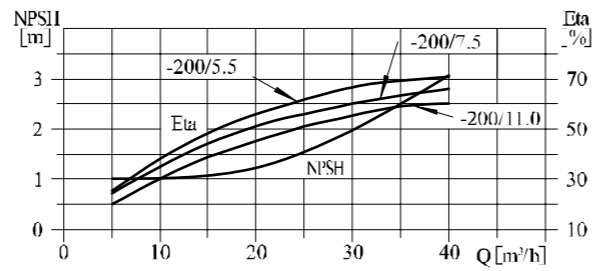
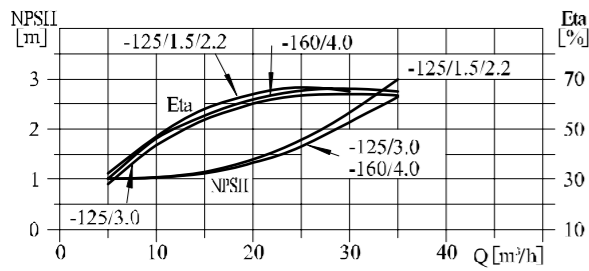
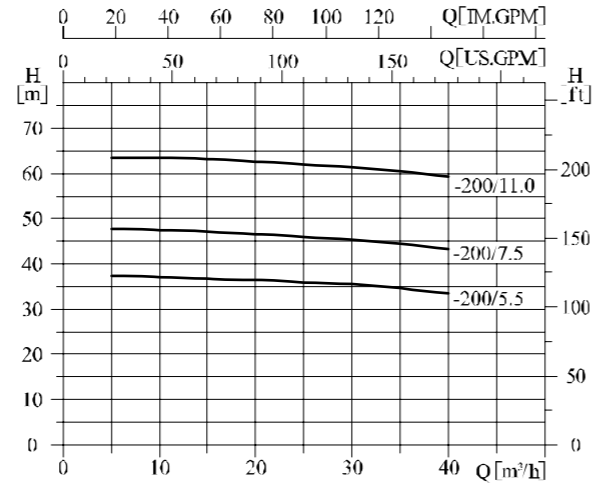
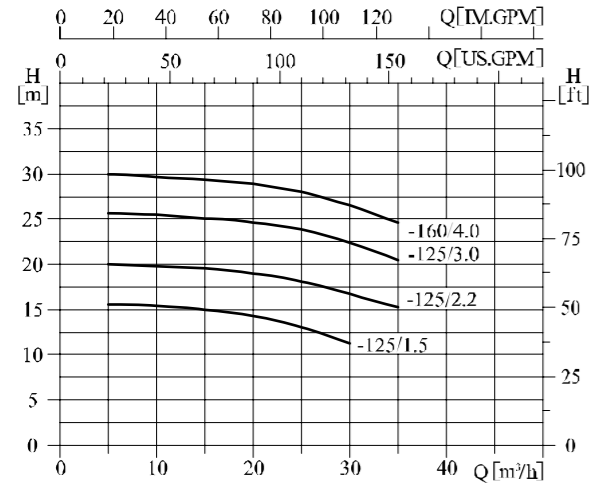

Performance table

Model	Driving motor (kW)		Q (m³/h)	5	10	15	20	25	30	35	40	
	(kW)	(hp)										
NSX, NSN 65-40-125/1.5	1.5	2	H (m)	15.5	15.4	15	14.4	13	11.3			
NSX, NSN 65-40-125/2.2	2.2	3		20	19.7	19.5	19	18	16.7	15.2		
NSX, NSN 65-40-125/3.0	3	4		25.7	25.3	25.1	24.8	24	22.3	20.3		
NSX, NSN 65-40-160/4.0	4	5.5		30	29.7	29.3	28.9	28	26.5	24.5		
NSX, NSN 65-40-200/5.5	5.5	7.5		37.4	37.2	36.7	36.4	36	35.5	34.6	33.3	
NSX, NSN 65-40-200/7.5	7.5	10		48	47.5	47	46.6	46	45.2	44.5	43.3	
NSX, NSN 65-40-200/11.0	11	15		64	63.5	63	62.5	62	61.5	60.5	59	

NSX, NSN 65-50

NSX, NSN 65-50-***

ISO9906 Annex A

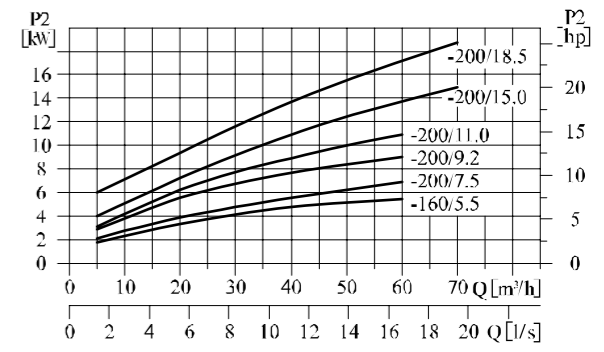
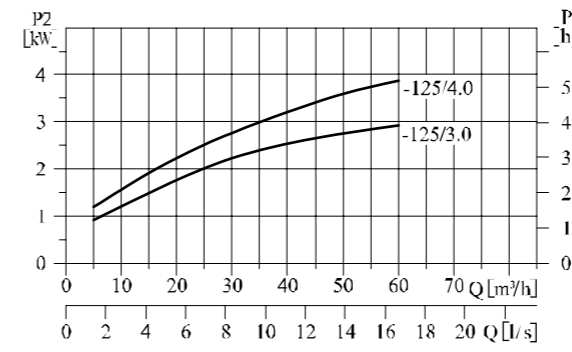
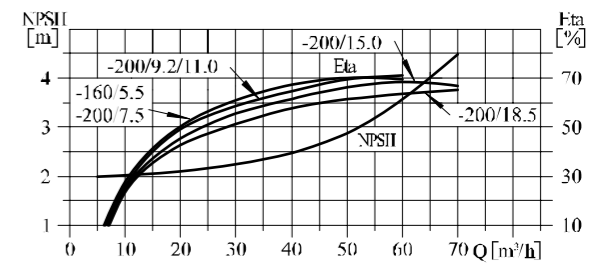
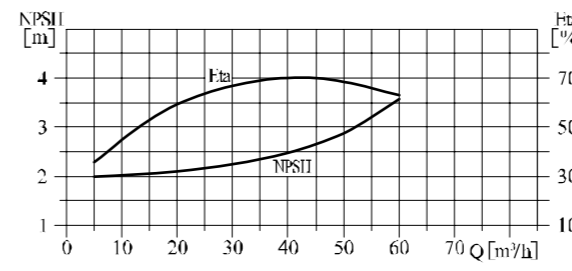
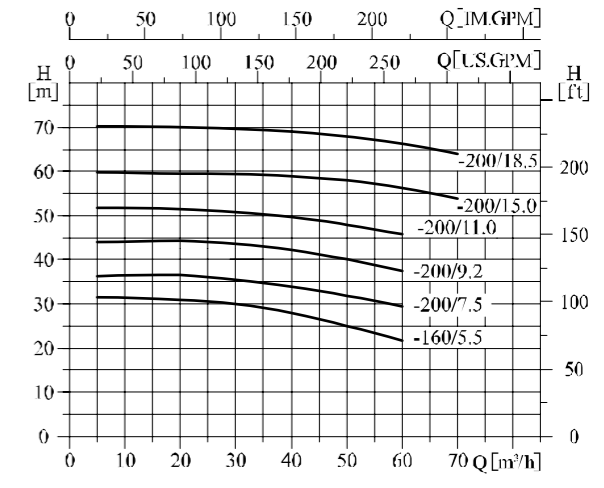
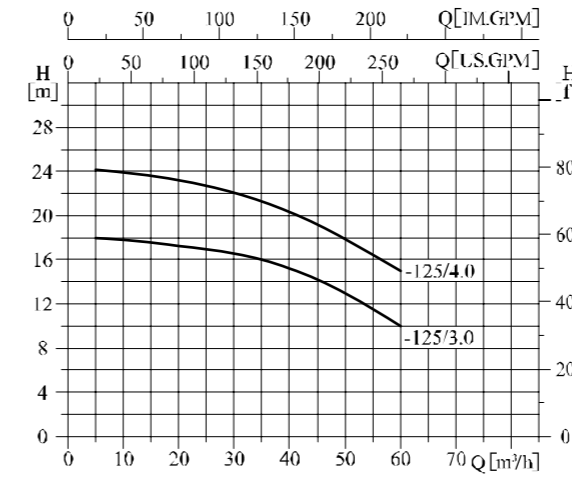

Performance table

Model	Driving motor (kW)		Q (m³/h)	5	10	20	30	40	50	60	70
	(kW)	(hp)									
NSX, NSN 65-50-125/3.0	3	4	H (m)	18	17.8	17.2	16.4	15.1	13	10	
NSX, NSN 65-50-125/4.0	4	5.5		24.2	24.2	23.6	22.6	20.7	18	14.8	
NSX, NSN 65-50-160/5.5	5.5	7.5		31.6	31.5	31	30	28	25	21.5	
NSX, NSN 65-50-200/7.5	7.5	10		36.3	36.6	36.4	35.6	34.1	32	29.6	
NSX, NSN 65-50-200/9.2	9.2	12.5		43.5	43.5	43.5	43	42	40	37.5	
NSX, NSN 65-50-200/11.0	11	15		51.5	51.5	51	50	49.3	48	45.6	
NSX, NSN 65-50-200/15.0	15	20		59.7	59.7	59.6	59.5	59	58	56.2	53
NSX, NSN 65-50-200/18.5	18.5	25		70.2	70.2	70.1	70	69.1	68	66.4	64

NSX, NSN 80-65

NSX, NSN 80-65-***:

ISO9906 Annex A

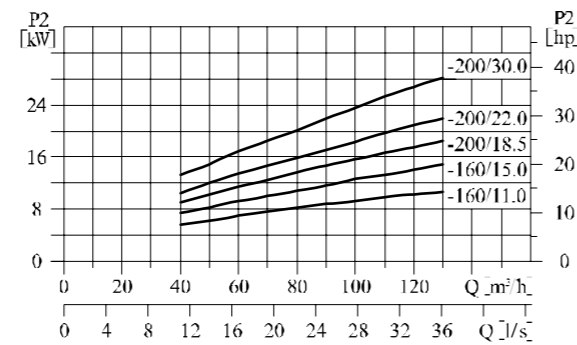
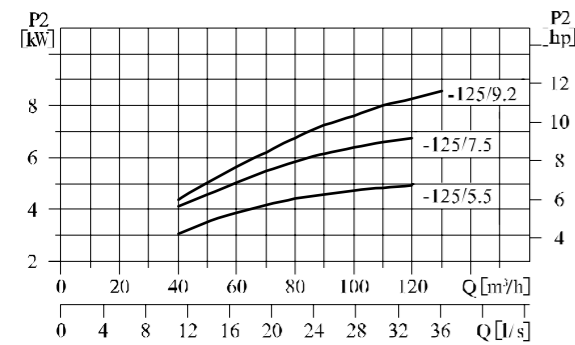
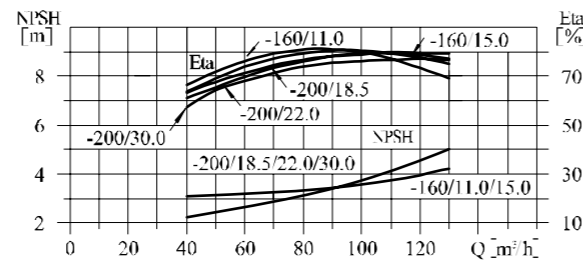
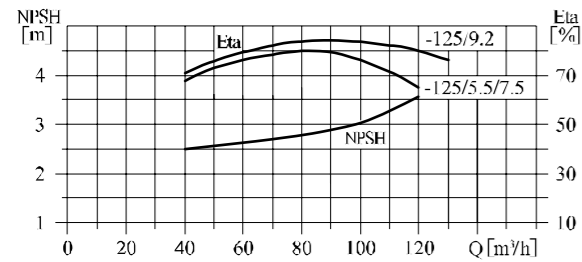
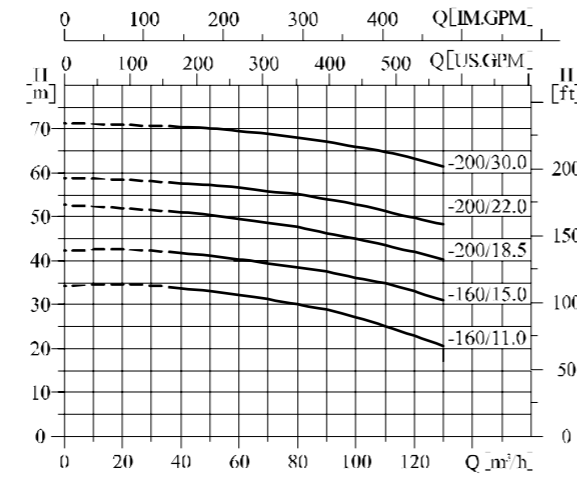
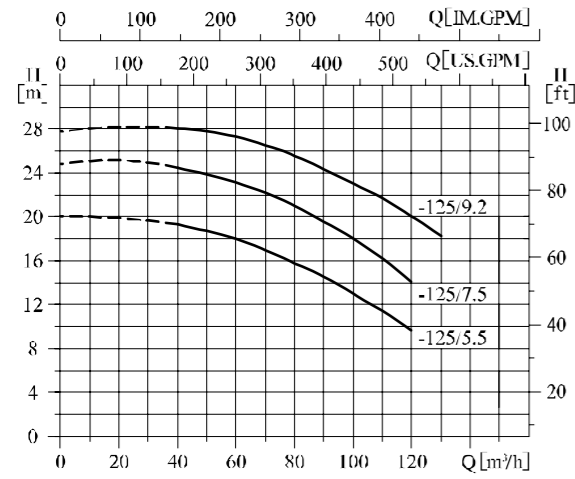

Performance table

Model	Driving motor (kW)		Q (m³/h)	H (m)											
	(kW)	(hp)		40	50	60	70	80	90	100	110	120	130		
NSX, NSN 80-65-125/5.5	5.5	7.5	H (m)	19.3	18.7	18	17	15.5	14.8	13	11.4	9.7			
NSX, NSN 80-65-125/7.5	7.5	10		24.5	23.8	23.1	22.2	21	19.6	18	16.2	14.1			
NSX, NSN 80-65-125/9.2	9.2	12.5		28.1	27.8	27.3	26.6	25.7	24.3	23	21.5	20.1	18.3		
NSX, NSN 80-65-160/11.0	11	15		33.9	33	32.2	31.3	29.9	28.8	27	25.1	22.9	20.7		
NSX, NSN 80-65-160/15.0	15	20		41.8	41.1	40.4	39.5	38.6	37.6	36	34.8	33	31		
NSX, NSN 80-65-200/18.5	18.5	25		51	50.5	49.6	48.7	47.6	46.3	45	43.5	42.2	40.2		
NSX, NSN 80-65-200/22.0	22	30		57.7	57.2	56.8	55.9	55.1	54	53	51.6	49.7	48.2		
NSX, NSN 80-65-200/30.0	30	40		70.2	70.2	69.6	68.9	68.2	67.1	66	64.6	63.3	61.4		

NSX, NSN 100-80

NSX, NSN 100-80-***

ISO9906 Annex A

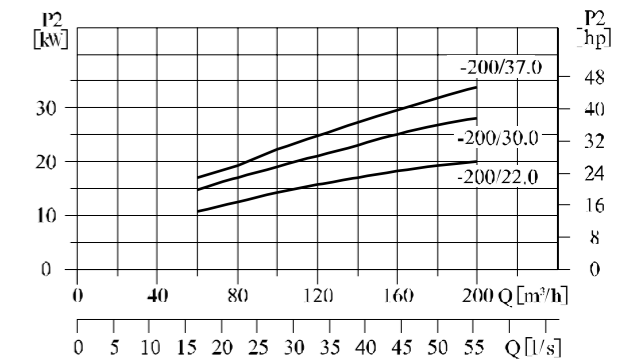
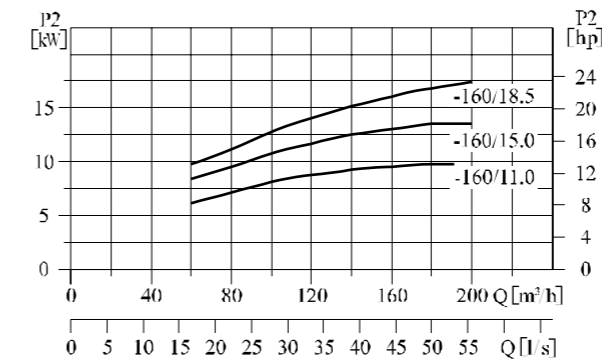
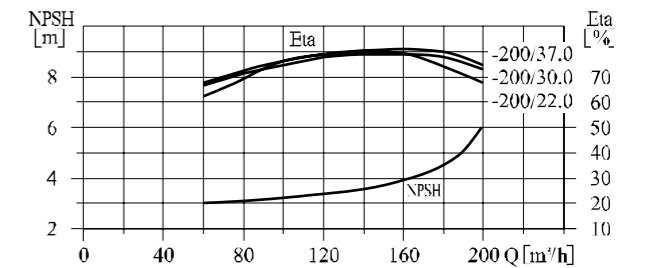
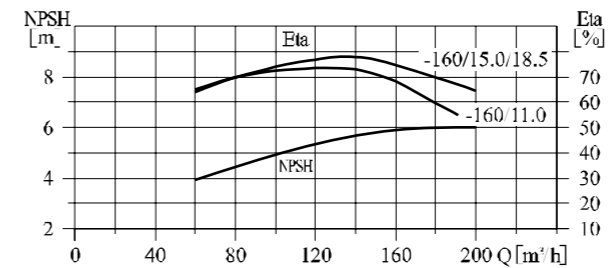
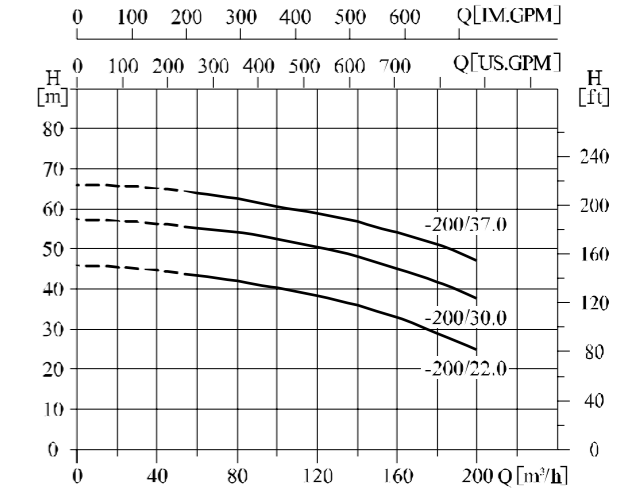
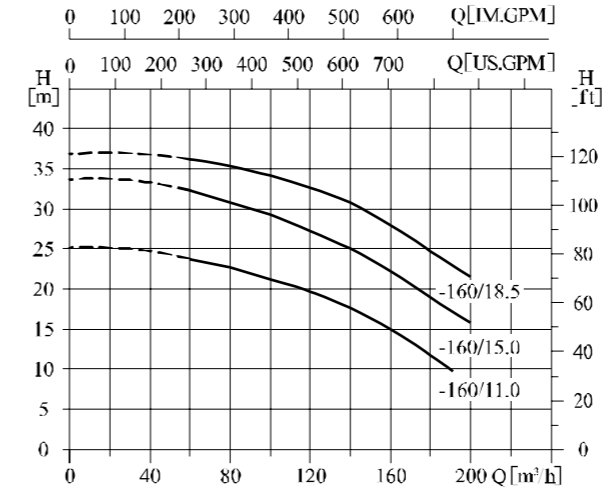

Performance table

Model	Driving motor (kW)		Q (m³/h)	H (m)									
	(kW)	(hp)		60	80	100	120	140	160	180	192	200	
NSX, NSN 100-80-160/11.0	11	15	H (m)	23.8	22.7	21.1	19.7	17.6	15	11.8	9.7		
NSX, NSN 100-80-160/15.0	15	20		32.3	30.8	29.1	27.2	25.1	22	18.8		16.1	
NSX, NSN 100-80-160/18.5	18.5	25		36.2	35.2	33.8	32.7	31	28	24.8		21.5	
NSX, NSN 100-80-200/22.0	22	30		43.5	42	39.7	38.3	35.9	33	29		24.9	
NSX, NSN 100-80-200/30.0	30	40		55.4	54.1	52.6	50.5	48.2	45	41.9		37.6	
NSX, NSN 100-80-200/37.0	37	50		64.1	62.5	61	59	57.4	54	51.2		47.1	

Installation sketch

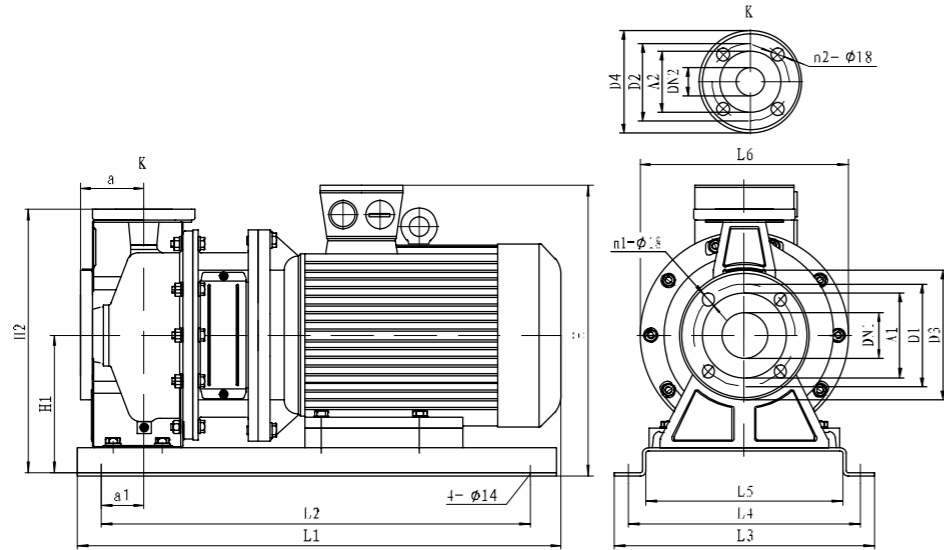

Size and weight

Model	Size (mm)																				Weight (kg)	
	DN1	DN2	A1	A2	D1	D2	D3	D4	n1	n2	a	a1	H	H1	H2	L1	L2	L3	L4	L5		L6
NSX, NSN 50-32-160/1.1	50	32	98	75	125	100	160	139	4	4	80	32	290	152	296	470	370	280	240	192	210	31
NSX, NSN 50-32-160/1.5	50	32	98	75	125	100	160	139	4	4	80	46	307	152	296	500	430	280	240	192	210	37
NSX, NSN 50-32-160/2.2	50	32	98	75	125	100	160	139	4	4	80	46	307	152	296	500	430	280	240	192	210	39
NSX, NSN 50-32-200/3.0	50	32	98	75	125	100	160	139	4	4	84	42	370	200	386	550	460	330	290	242	300	53
NSX, NSN 50-32-200/4.0	50	32	98	75	125	100	160	139	4	4	84	47	393	200	386	560	480	330	290	242	300	58
NSX, NSN 50-32-200/5.5	50	32	98	75	125	100	160	139	4	4	84	50	413	200	386	660	580	370	330	280	300	77
NSX, NSN 65-40-125/1.5	65	40	118	84	145	110	185	145	4	4	80	45	307	152	294	502	430	280	240	192	210	33
NSX, NSN 65-40-125/2.2	65	40	118	84	145	110	185	145	4	4	80	45	307	152	294	502	430	280	240	192	210	35
NSX, NSN 65-40-125/3.0	65	40	118	84	145	110	185	145	4	4	80	45	322	152	294	532	460	300	260	212	250	47
NSX, NSN 65-40-160/4.0	65	40	118	84	145	110	185	145	4	4	80	45	345	152	294	557	480	330	290	242	250	52
NSX, NSN 65-40-200/5.5	65	40	118	84	145	110	185	145	4	4	100	50	413	200	380	680	580	370	330	280	300	78
NSX, NSN 65-40-200/7.5	65	40	118	S4	145	110	135	145	4	4	100	50	413	200	380	680	580	370	330	280	300	82
NSX, NSN 65-40-200/11.0	65	40	118	84	145	110	185	145	4	4	100	50	456	200	380	790	690	420	380	330	350	161
NSX, NSN 65-50-125/3.0	65	50	118	98	145	125	185	160	4	4	86	45	342	172	338	548	468	330	290	242	250	49
NSX, NSN 65-50-125/4.0	65	50	118	98	145	125	185	160	4	4	86	45	365	172	338	570	490	330	290	242	250	54
NSX, NSN 65-50-160/5.5	65	50	118	98	145	125	185	160	4	4	100	50	413	200	380	680	580	370	330	280	300	78
NSX, NSN 65-50-200/7.5	65	50	118	98	145	125	185	160	4	4	100	50	413	200	380	680	580	370	330	280	300	82
NSX, NSN 65-50-200/9.2	65	50	118	98	145	125	185	160	4	4	100	50	413	200	380	680	580	370	330	280	300	85
NSX, NSN 65-50-200/11.0	65	50	118	98	145	125	185	160	4	4	100	50	456	200	380	790	690	420	380	330	350	161
NSX, NSN 65-50-200/15.0	65	50	118	98	145	125	185	160	4	4	100	50	456	200	380	790	690	420	380	330	350	171
NSX, NSN 65-50-200/18.5	65	50	118	98	145	125	185	160	4	4	100	50	456	200	380	830	730	420	380	330	350	188
NSX, NSN 80-65-125/5.5	80	65	130	118	160	145	200	185	8	4	100	50	413	200	380	690	590	370	330	280	300	79
NSX, NSN 80-65-125/7.5	80	65	130	118	160	145	200	185	8	4	100	50	413	200	380	690	590	370	330	280	300	83
NSX, NSN 80-65-125/9.2	80	65	130	118	160	145	200	185	8	4	100	50	413	200	380	690	590	370	330	280	300	87
NSX, NSN 80-65-160/11.0	80	65	130	118	160	145	200	185	8	4	100	50	456	200	400	790	690	420	380	330	350	163
NSX, NSN 80-65-160/15.0	80	65	130	118	160	145	200	185	8	4	100	50	456	200	400	790	690	420	380	330	350	173
NSX, NSN 80-65-200/18.5	80	65	130	118	160	145	200	185	8	4	100	50	476	220	445	830	730	420	380	330	350	190
NSX, NSN 80-65-200/22.0	80	65	130	118	160	145	200	185	8	4	100	50	500	220	445	880	780	455	415	365	350	220
NSX, NSN 80-65-200/30.0	80	65	130	118	160	145	200	185	8	4	100	50	550	240	465	950	850	495	455	405	400	292
NSX, NSN 100-80-160/11.0	100	80	150	130	180	160	220	200	8	8	125	75	476	220	445	830	730	420	380	330	350	163
NSX, NSN 100-80-150/15.0	100	80	150	130	180	160	220	200	8	8	125	75	476	220	445	830	730	420	380	330	350	173
NSX, NSN 100-80-150/18.5	100	80	150	130	180	160	220	200	8	8	125	75	476	220	445	870	770	420	380	330	350	185
NSX, NSN 100-80-200/22.0	100	80	150	130	180	160	220	200	8	8	125	75	500	220	470	915	810	455	415	365	350	223
NSX, NSN 100-80-200/30.0	100	80	150	130	180	160	220	200	8	8	125	75	550	240	490	985	880	495	455	405	400	295
NSX, NSN 100-80-200/37.0	100	80	150	130	180	160	220	200	8	8	125	75	550	240	490	985	880	495	455	405	400	315

